

# DISCOVER THE GLOW-WORM BOILER RANGE

Plumb Centre Range Brochure



glow  worm

PLUMB  
CENTRE 

# KEEPING BRITAIN GLOWING

## We've been keeping people cosy for 90 years

Our product ranges are made for homes that are there to be lived in, not looked at. Whether it's the hot shower after football training or toasty socks straight off the radiator, we provide that warm flow that keeps everyone going.

Not only this, but they're easy to fit, reliable and backed by exceptional support, with more installer perks than you can shake a spanner at.

## Who we are

Glow-worm is a cornerstone of the UK heating industry, nestled in the heart of Derbyshire. Since 1934, our focus has been on building robust, high-efficiency boilers, controls and accessories that provide the families of Britain with the warmth and hot water they need, when they need it.

In 2001, we were acquired by the Vaillant Group, one of Europe's largest heating appliance manufacturers. Its investment has enabled us to expand our product offering and develop innovative new technologies – while keeping our roots at our state-of-the-art factory in Belper.

As part of Vaillant Group, Glow-worm is proud to have achieved both Investors in People Gold and Health and Wellbeing awards.

---

Rated **Excellent** on  **Trustpilot**



## Contents

# Say hello to the range

## The Energy<sub>7</sub> range



**Combi boiler**  
See page 4

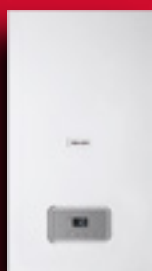

**System boiler**  
See page 6



**Regular boiler**  
See page 8

## The Compact range



**Combi boiler**  
See page 10



**LPG boiler**  
See page 12



---

Power System Filter .....	14	The right part for every job .....	30
Smart controls.....	16	Training with Glow-worm .....	32
Bathroom zoning .....	19	Club Energy .....	34
Flue options .....	20	Technical support .....	35

# Energy<sub>7</sub> Combi Boiler

Our Energy<sub>7</sub> combi range combines an attractive modern design with exceptional performance. Light and compact, with a choice of top or rear flue, it's a dream to fit. The automotive-grade aluminium heat exchanger has large waterways that make it ideal for retrofit jobs. Patented four-sided cooling reduces the strain on the heat exchanger to improve reliability. Homeowners love the extra reassurance of up to a 10-year guarantee.\*



**MADE IN BRITAIN**



FREE 10-year guarantee\*



Earn £50 cashback when registered with the Glow-worm Power System Filter



Top and rear flue options available



Manufactured in our award-winning factory in Derbyshire



Compatible with our Power System Filter



Ultra-quiet operation\*\*

## Features and benefits

- Superior-quality parts have longevity and are easy to maintain
- Small footprint for easier installation and dimensions suitable to be installed in a standard cupboard
- Modern LCD display offers excellent clarity, even in dimly lit rooms
- Top and rear flue options offer flexibility to fit most install situations and is perfect for retrofit
- Works with Glow-worm's entire range of intelligent controls
- Quiet Mark approval means ultra-quiet operation for homeowners\*\*

\*When installed with a Glow-worm Power System Filter and registered through Club Energy.

\*\*25kW Energy<sub>7</sub> combi boiler.

# Energy<sub>7</sub> combi technical specification

## Energy<sub>7</sub> combi dimensions

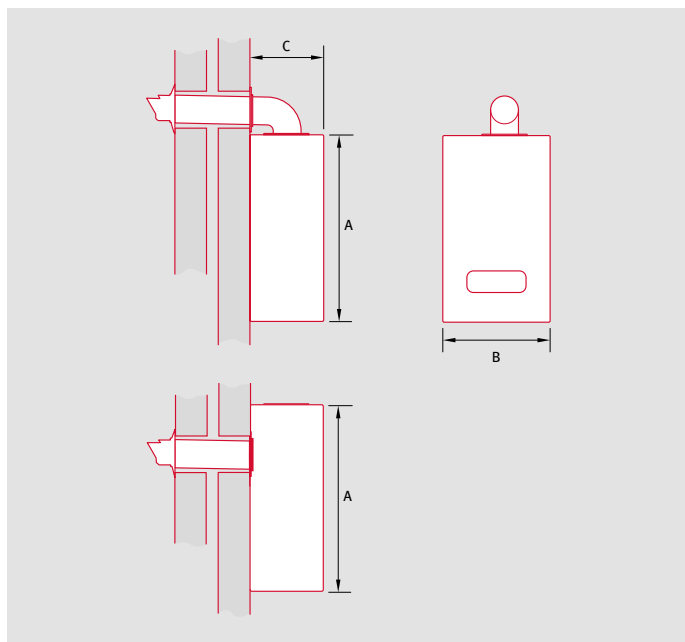

Boiler dimensions		
Height (A)	Width (B)	Depth (C)
700mm	390mm	280mm

## Energy<sub>7</sub> combi clearances



Boiler clearances			
Top	Side	Bottom	Front
205mm*	5mm	150mm	600mm**

\*Reduced to 20mm if using a rear flue.

\*\*5mm if removable panel or door.

	Unit of measure	25c	30c	35c
<b>General</b>				
Boiler type		Combi	Combi	Combi
Model output	kW	25	30	35
Article number		0010035896	0010035897	0010035898
Gas Council number		47-019-60	47-019-61	47-019-62
Lift weight	kg	32	33	33
<b>Performance</b>				
NOx (En 15502-2-1)	mg/kWh	39	39	39
ErP efficiency	%	94	94	94
ErP decibel rating (sound power)	dBa	49	51	52
ErP efficiency Heating/DHW	A+++ to D / A+ to F	A/A	A/A	A/A
PCDB annual efficiency (SAP 2009/2012)	%	89.6	89.7	89.7
<b>Heating and hot water</b>				
Hot water flow rate (ΔT 35°C)	l/min	10.4	12.2	14.1
<b>Flue</b>				
Max flue length - horizontal/vertical (60/100)	m	10/10	10/10	10/10
Max flue length - horizontal/vertical (80/125)	m	25/25	25/25	25/25
Rear flue	Yes/No	Yes	Yes	Yes

# Energy<sub>7</sub> System Boiler

Our Energy<sub>7</sub> system boiler range is great for homes with high hot water demands and can be installed with a range of cylinders for hot water storage. Light and compact, yet perfectly formed, it's a breeze to fit, especially with its choice of top or rear flue options. Servicing is easy too, with simple water flush cleaning that doesn't need any special tools or chemicals. The combination of automotive-grade materials and patented four-sided cooling means the heat exchanger lasts longer and gives homeowners the reliability they expect from their boiler. Plus, the nationwide availability of parts makes repairs simpler.



**MADE IN BRITAIN**



FREE 10-year guarantee\*



Earn cashback when installs are registered through Club Energy



Top and rear flue options available



Manufactured in our award-winning factory in Derbyshire



Compatible with our Power System Filter



Ultra-quiet operation\*\*

## Features and benefits

- Superior-quality parts have longevity and are easy to maintain
- Small footprint for easier installation and dimensions suitable to be installed in a standard cupboard
- Modern LCD display offers excellent clarity, even in dimly lit rooms
- Top and rear flue options offer flexibility to fit most install situations and is perfect for retrofit
- Works with Glow-worm's entire range of intelligent controls
- Quiet Mark approval means ultra-quiet operation for homeowners\*\*

\*When installed with a Glow-worm Power System Filter and registered through Club Energy.

\*\*18kW and 25kW Energy, system boilers.

# Energy<sub>7</sub> system technical specification

## Energy<sub>7</sub> system dimensions

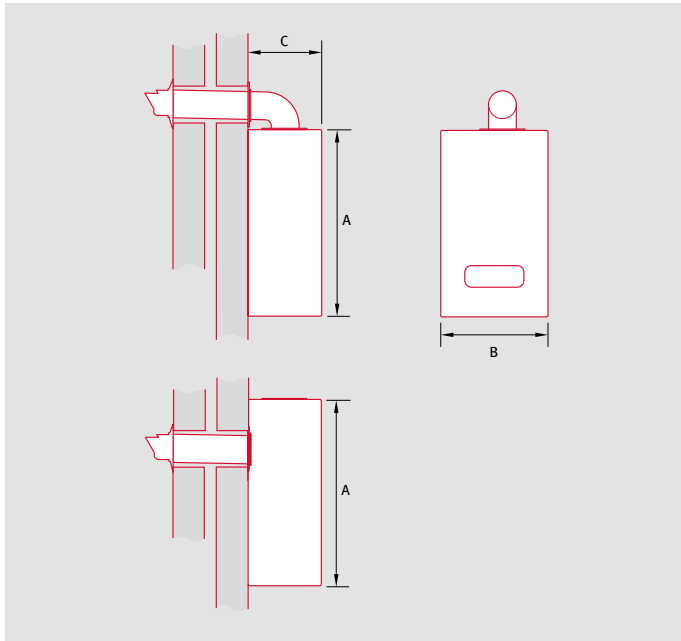

Boiler dimensions

Height (A)	Width (B)	Depth (C)
700mm	390mm	280mm

## Energy<sub>7</sub> system clearances



Boiler clearances

Top	Side	Bottom	Front
205mm*	5mm	150mm	600mm**

\*Reduced to 20mm if using a rear flue.

\*\*5mm if removable panel or door.

	Unit of measure	12s	15s	18s	25s	30s
<b>General</b>						
Boiler type		System	System	System	System	System
Model output	kW	12	15	18	25	30
Article number		0010035899	0010035900	0010035901	0010035902	0010035903
Gas Council number		41-019-53	41-019-54	41-019-55	41-019-56	41-019-57
Lift weight	kg	31	31	31	32	32
<b>Performance</b>						
NOx (En 15502-2-1)	mg/kWh	33	32	39	39	40
ErP efficiency	%	94	94	94	94	94
ErP decibel rating (sound power)	dBa	45	48	49	51	54
ErP efficiency Heating/DHW	A+++ to D / A+ to F	A/-	A/-	A/-	A/-	A/-
PCDB annual efficiency (SAP 2009/2012)	%	89.8	89.8	89.7	89.8	89.8
<b>Flue</b>						
Max flue length - horizontal/vertical (60/100)	m	10/10	10/10	10/10	10/10	10/10
Max flue length - horizontal/vertical (80/125)	m	25/25	25/25	25/25	25/25	25/25
Rear flue	Yes/No	Yes	Yes	Yes	Yes	Yes

# Energy<sub>7</sub> Regular Boiler

Our Energy<sub>7</sub> regular boiler, otherwise known as an open vent boiler, can be paired with a wide range of Glow-worm controls to create the perfect heating system for homeowners. It's especially useful for those high hot water demands and can be installed with a range of cylinders for hot water storage. Despite its heavyweight performance, the Energy<sub>7</sub> regular is lightweight, compact and easy to install. The choice of top or rear flue offers flexibility, particularly when it comes to retrofitting. We use patented four-sided cooling to reduce stress on the high-quality heat exchanger, delivering reliability homeowners can really get behind.



**MADE IN BRITAIN**



FREE 10-year guarantee\*



Earn cashback when registered with a filter through Club Energy



Top and rear flue options available



Manufactured in our award-winning factory in Derbyshire

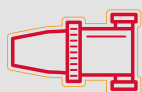

Compatible with our Power System Filter

## Features and benefits

- Superior-quality, automotive-grade heat exchanger lasts longer and is easier to maintain
- Easy to clean heat exchanger – simply flush with water
- Small footprint for easier installation and dimensions suitable to be installed in a standard cupboard
- Modern LCD display offers excellent clarity, even in dimly lit rooms
- Top and rear flue options offer flexibility to fit most install situations and is perfect for retrofit
- Works with Glow-worm's entire range of intelligent controls

\*When installed with a Glow-worm Power System Filter and registered through Club Energy.



# Energy, regular technical specification

## Energy, regular dimensions

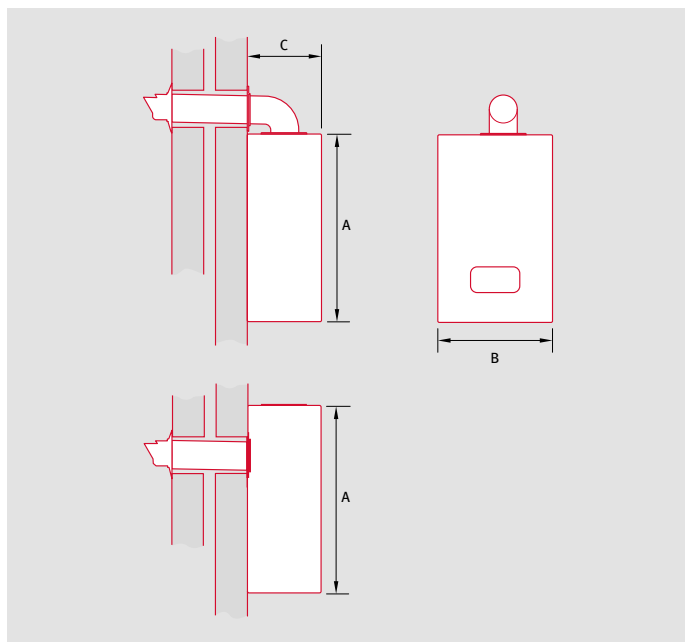

Boiler dimensions		
Height (A)	Width (B)	Depth (C)
600mm	375mm	280mm

## Energy, regular clearances



Boiler clearances			
Top	Side	Bottom	Front
205mm*	5mm	150mm	600mm**

\*Reduced to 20mm if using a rear flue.

\*\*5mm if removable panel or door.

	Unit of measure	12r	15r	18r	25r	30r
<b>General</b>						
Boiler type		Regular	Regular	Regular	Regular	Regular
Model output	kW	12	15	18	25	30
Article number		0010035904	0010035905	0010035906	0010035907	0010035908
Gas Council number		41-019-58	41-019-59	41-019-60	41-019-61	41-019-62
Lift weight	kg	22	22	22	22	22
<b>Performance</b>						
NOx (En 15502-2-1)	mg/kWh	33	32	39	39	39
ErP efficiency	%	94	94	94	94	94
ErP decibel rating (sound power)	dBa	45	48	49	52	55
ErP efficiency Heating/DHW	A+++ to D / A+ to F	A/-	A/-	A/-	A/-	A/-
PCDB annual efficiency (SAP 2009/2012)	%	89.8	89.8	89.7	89.8	89.8
<b>Flue</b>						
Max flue length - horizontal/vertical (60/100)	m	10/10	10/10	10/10	10/10	10/10
Max flue length - horizontal/vertical (80/125)	m	25/25	25/25	25/25	25/25	25/25
Rear flue	Yes/No	Yes	Yes	Yes	Yes	Yes

# Compact Combi Boiler

They say great things come in small packages, and that's exactly what you get with the Compact combi boiler. It's the most compact and lightweight boiler we've ever produced, but don't let its stature fool you – this boiler delivers big performance. It's sturdy and delivers the reliability your customers love. It's also a dream to install, saving you time, hassle and bruised knuckles. With a stainless steel heat exchanger, it also ensures a durable long-lasting performance.



FREE out-of-the-box 5-year guarantee



Earn 30 credits to spend on exclusive Glow-worm merchandise when registered on Club Energy



Stainless steel heat exchanger



Compatible with our Power System Filter

## Features and benefits

- Small footprint allows for flexible, fast installation
- User-friendly display for quick and easy commissioning
- 25mm spacer frame enables piping behind the boiler while still fitting in a standard 300mm cupboard
- Optional analogue clock can be fitted easily without removing the boiler case
- Optional pipe accessory for the central heating return to bring the connections in line with traditional domestic boiler layouts

# Compact combi technical specification

## Compact combi dimensions

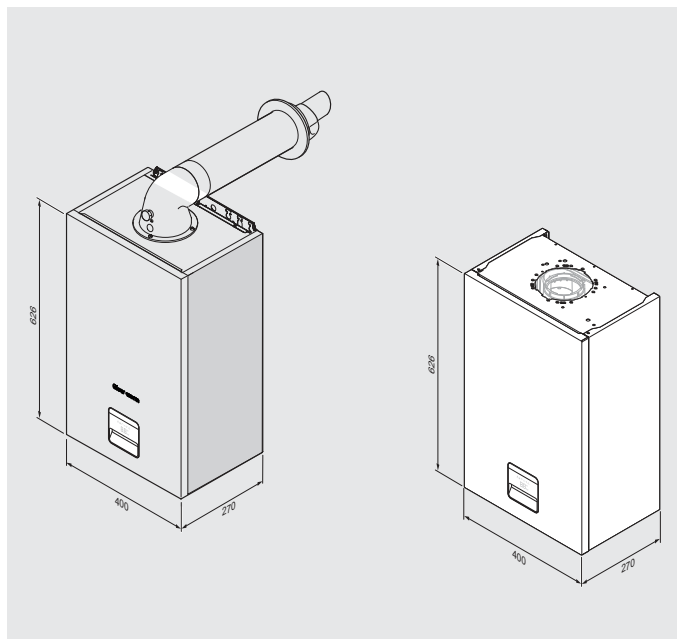

Boiler dimensions

Height (A)	Width (B)	Depth (C)
626mm	400mm	270mm

## Compact combi clearances



Boiler clearances

Top	Side	Bottom	Front
205mm	5mm	180mm	500mm*

\*5mm if removable panel or door.

	Unit of measure	24c	28c
<b>General</b>			
Boiler type		Combi	Combi
Model output	kW	24	28
Article number		0010040105	0010040106
Gas Council number		47-019-63	47-019-64
Lift weight	kg	25.6	26.5
<b>Performance</b>			
NOx (En 15502-2-1)	mg/kWh	27	32
ErP efficiency	%	92	93
ErP decibel rating (sound power)	dBa	52	54
ErP efficiency Heating/DHW	A+++ to D / A+ to F	A/A	A/A
<b>Heating and hot water</b>			
Hot water flow rate (T 35 C)	l/min	9.9	11.5
<b>Flue</b>			
Max flue length - horizontal/vertical (60/100)	m	9/10	9/10
Max flue length - horizontal/vertical (80/125)	m	25/25	25/25
Rear flue	Yes/No	No	No

# Compact LPG Boiler

The Compact LPG boiler packs great performance into its small proportions. Its robust build means it's dependable and long-lasting, with a high-efficiency pump to keep costs low for your customers. With flexible flue spacing and hassle-free maintenance, it's easy for you to install and maintain too.



FREE out-of-the-box 5-year guarantee



Earn 30 credits to spend on exclusive Glow-worm merchandise when registered on Club Energy



Stainless steel heat exchanger



Compatible with our Power System Filter

## Features and benefits

- Small footprint allows for flexible, fast installation
- User-friendly display for quick and easy commissioning
- 25mm spacer frame enables piping behind the boiler while still fitting in a standard 300mm cupboard
- Optional analogue clock can be fitted easily without removing the boiler case
- Optional pipe accessory for the central heating return to bring the connections in line with traditional domestic boiler layouts

# Compact LPG technical specification

## Compact LPG dimensions

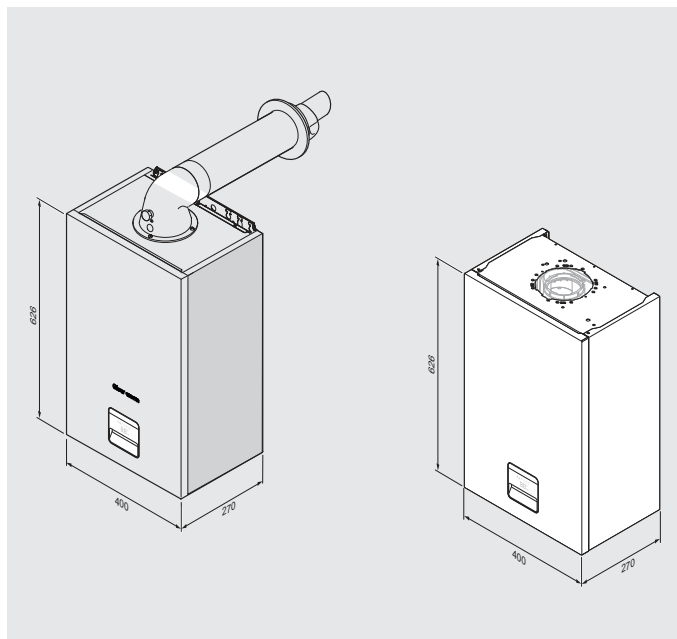

Boiler dimensions

Height (A)	Width (B)	Depth (C)
626mm	400mm	270mm

## Compact LPG clearances



Boiler clearances

Top	Side	Bottom	Front
205mm	5mm	180mm	500mm*

\*5mm if removable panel or door.

	Unit of measure	24 (LPG)	28 (LPG)
<b>General</b>			
Boiler type		Combi	Combi
Model output	kW	24	28
Article number		0010040107	0010040108
Gas Council number		47-019-65	47-019-66
Lift weight	kg	25.6	26.5
<b>Performance</b>			
NOx (En 15502-2-1)	mg/kWh	27	32
ErP efficiency	%	92	93
ErP decibel rating (sound power)	dBa	52	54
ErP efficiency Heating/DHW	A+++ to D / A+ to F	A/A	A/A
<b>Heating and hot water</b>			
Hot water flow rate (T 35 C)	l/min	9.9	11.5
<b>Flue</b>			
Max flue length - horizontal/vertical (60/100)	m	9/10	9/10
Max flue length - horizontal/vertical (80/125)	m	25/25	25/25
Rear flue	Yes/No	No	No

# A decade of positive Energy guaranteed

Our Power System Filter has been designed to give you even more confidence in the reliability of our products. Its compact yet robust build helps prolong the life of our boilers and deliver the long-term performance homeowners desire.

We're backing up this reliability pledge with an up to 10-year guarantee on selected boiler ranges\* and Power System Filters when they're installed together and both registered through Club Energy. Servicing is a cinch, and replacement O-rings are available as a spare part.



Designed by Glow-worm for use with Glow-worm boilers



FREE 10-year guarantee\*

\*10-year guarantee only applies when filter is fitted with an Energy boiler and registered on Club Energy.

## What's in the box?

The Glow-worm Power System Filter comes with an installation and operational manual, and an isolation valve.

## Features and benefits

- Horizontal siting provides a more discreet, space-saving fit
- Compact design allows more flexible, less intrusive siting options
- High-quality brass body guarantees long-lasting performance
- Composite front section removes unnecessary weight
- Easy disassembly makes servicing faster
- Hard-wearing stainless steel mesh collects non-magnetic debris and blocks sludge from entering the boiler
- Suitable for boilers located in any area
- Perfect for boilers installed in cold areas where glycol has been added to protect from freezing
- Can connect to a standard hose, so the drain point can also be used for dosing. The unique sealing ring and swivel head allows it to rotate without leaking for easier serviceability
- Ideal for modern systems as well as older, high-temperature systems

# Power System Filter technical specification

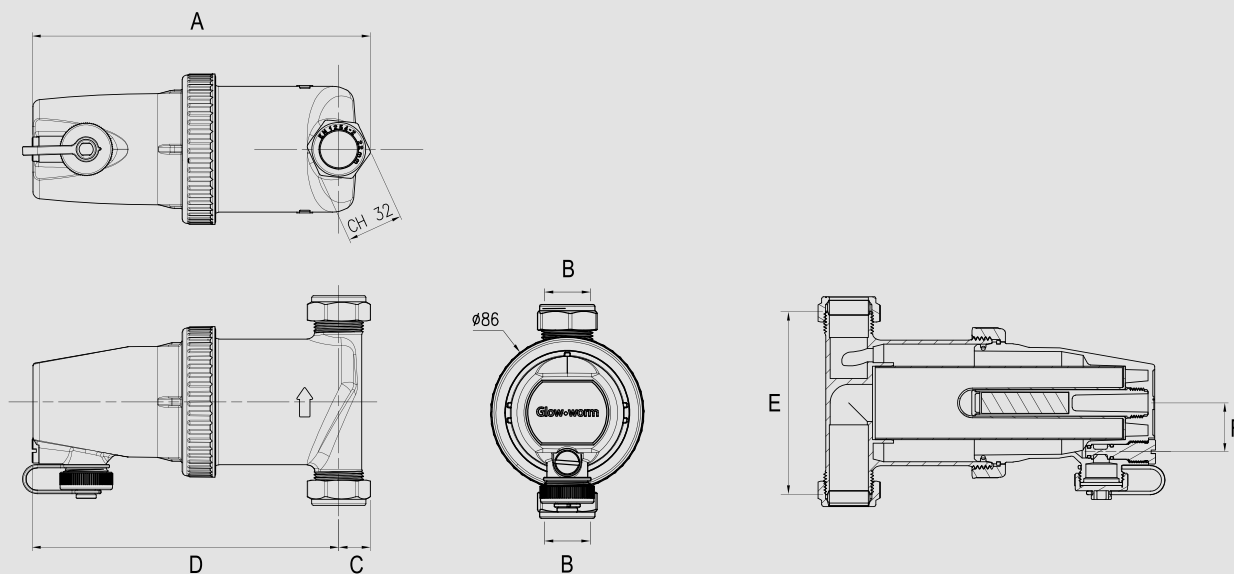

Technical data	Unit	Power System Filter
22mm fitting only		
A	mm	194
B	mm	22
C	mm	18
D	mm	176
E	mm	105
F	mm	28

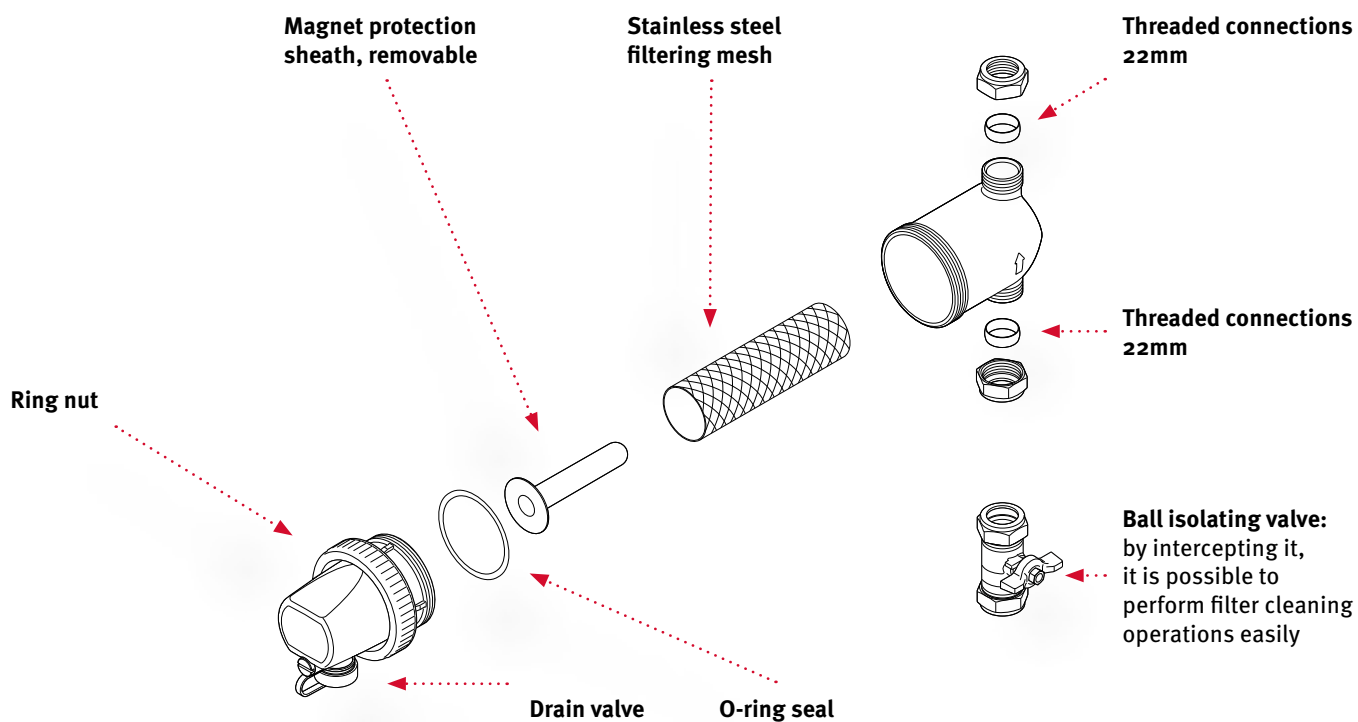

# Elevate your installs with our smart controls

Glow-worm's wide range of controls has something to suit every customer, from simple room thermostats to wireless, app-controlled options. What's more, with the MiGo Link internet gateway, you can offer your customers additional smart home connectivity features, including voice commands with Amazon Alexa and Apple HomeKit!

You'll enjoy the easy fitting while homeowners will love the convenience and comfort they offer. When added to a combi boiler, our intelligent controls also help you comply with Boiler Plus legislation.



## MiSet

### Key features:

- Wall-mounted programmable room thermostat
- Responsive semi-touch interface makes it easy to manage heating
- Time programme assistant helps homeowners set heating programmes in minutes
- User-friendly operation for hassle-free heating adjustments
- Enhanced load compensation adjusts output to ensure efficient energy usage
- Available as a wired or wireless model
- Capable of controlling two heating zones with a wired MiSet and SR 92
- Load compensating out of the box, but may be installed with an outdoor sensor for weather compensation
- Access to the MiGo Link app when installed with the MiGo Link internet gateway

## MiGo Select

### Key features:

- The MiGo Select is a wireless thermostat that can be mounted or left on a surface in any room
- Smart but simple, the thermostat is easy to use and will monitor the room temperature and room air humidity
- Install with the MiGo Link internet gateway which will act as both the receiver and internet gateway to control the system with the MiGo Link app
- Compatible with single zone heating systems
- Access to the MiGo Link app when installed with the MiGo Link internet gateway





# Climastat Select

## Key features:

- Wall-mounted room thermostat
- Enhanced load compensation ensures energy-efficient boiler use via eBUS connection
- Combines with mechanical timers to provide low-cost Boiler Plus compliance
- Service, fault and maintenance indication for convenience
- Clear digital display and wide temperature range (5-30 degrees) makes life easy for homeowners
- Access to the MiGo Link app when installed with the MiGo Link internet gateway



# Climapro<sub>2</sub>

## Key features:

- Two-channel wireless programmable room thermostat
- Handheld remote gives homeowners complete control of their heating and hot water from the comfort of their armchair
- Weather compensation automatically keeps homeowners cosy when it gets cold
- Straightforward menus allow homeowners to easily set their heating to suit their lifestyle and timetable
- eBUS connection lets the boiler modulate to deliver optimum efficiency

# MiGo Link Internet Gateway

## Key features:

- Compatible with Glow-worm's MiSet, MiGo Select and Climastat Select controls and allows your customers to control their heating on the go using the MiGo Link app
- Compatible with all current Glow-worm boilers
- Enables weather compensation when installed with either a MiGo Select or Climastat Select
- Simple installation with the new SRA 42 adapter which allows for power and eBUS to be taken directly from the boiler PCB\*
- Easily connects to Amazon Alexa or Apple HomeKit for additional smart home connectivity, allowing your customers to control their heating and hot water with voice commands\*\*



# MiGo Link app

## Key features:

- Your customers heating and hot water requirements can be accessed from one central place
- Allows your customers to see their heating's status at a glance
- View heating patterns and hot water consumption to monitor energy usage
- The MiGo Link internet gateway must be fitted with a MiSet, Climastat Select or MiGo Select control to allow total control of heating and hot water through the MiGo Link app
- Compatible with Amazon Alexa and Apple HomeKit

\*Depending on appliance type.

\*\*Only suitable for single heating zone systems.

# Intelligent controls

## Range line-up



	MiSet	MiGo Select	Climastat Select	Climapro <sub>2</sub>
Room thermostat		✓	✓	
Programmable thermostat	✓			✓
Compatible with the MiGo Link internet gateway	✓	✓	✓	
eBUS communication	✓	✓	✓	✓
Load compensation	✓	✓	✓	✓
24-hour timer	✓	Via MiGo Link app	✓****	✓
7-day programming	✓	Via MiGo Link app	✓****	✓
Heating	✓	✓	✓	✓
Hot water	✓	Via MiGo Link app	When installed with MiGo Link internet gateway	✓
Holiday mode	✓	Via MiGo Link app	When installed with MiGo Link internet gateway	✓
Wired or wireless	Wired or wireless	Wireless	Wired	Wireless
Weather compensation	✓*	Via MiGo Link app	When installed with MiGo Link internet gateway	✓*
Remote app control	When installed with MiGo Link internet gateway	When installed with MiGo Link internet gateway	When installed with MiGo Link internet gateway	
ErP efficiency class	V	VI	V***	V
ErP efficiency benefit	+3%	+4%	+3%***	+3%
Zoning	2**	1	1	1

\*Weather compensating with additional outdoor sensor.

\*\*2 zones achievable with wired models only.

\*\*\*Climastat Select installed with MiGo Link reaches ERP class VI and a benefit of +4%.

\*\*\*\*Dependant on if the Climastat Select is installed with a timer or MiGo link.

# Bathroom zoning

## Classification of zones

As all Glow-worm Energy<sub>7</sub> boilers are IPX4D rated, they can be installed in zone 2 of a bathroom. Boilers should not be installed in zone 0 or zone 1.

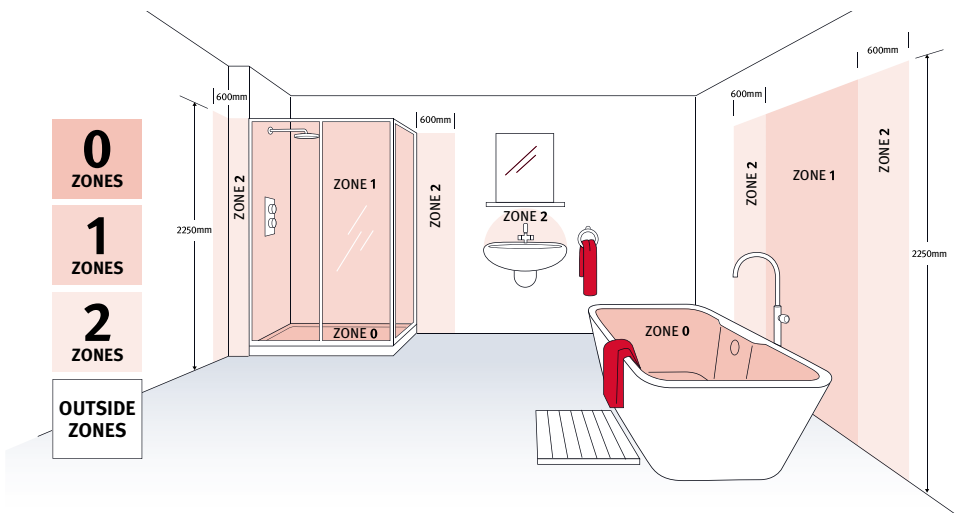
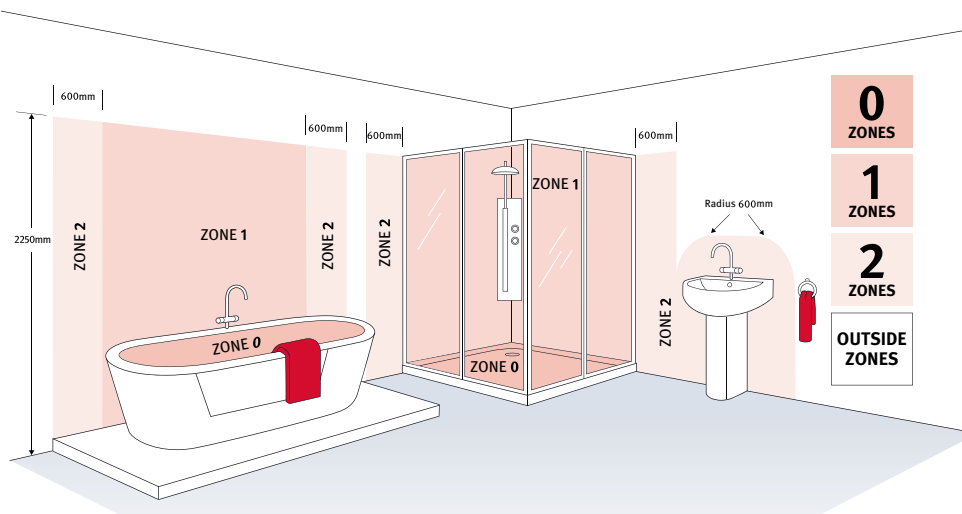
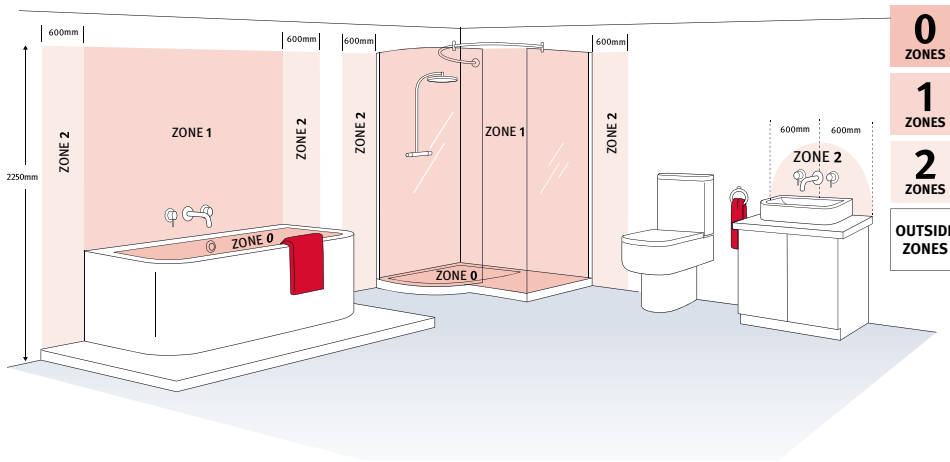

### Zone 0:

The interior of the bath or shower tray.

### Zone 1:

The exterior of the bath or shower tray to a height of 2.25 metres above the finished floor level.

### Zone 2:

Extends to 0.60 metres beyond zone 1 to a height of 2.25 metres above the finished floor level.

### Zone 3 (Outside Zones):

Refers to any position outside of zones 1 and 2.

# Flue options

The flueing options below are for our Energy<sub>7</sub> and Compact ranges (60/100).

## Horizontal top side flue (standard)

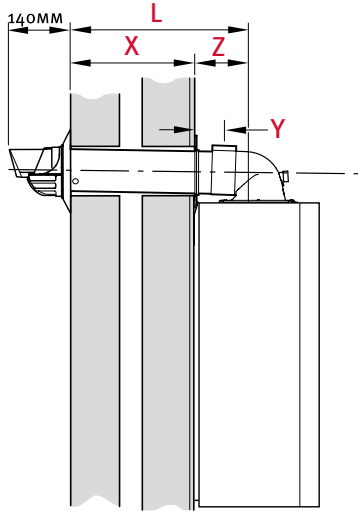

L = Flue length, measured from outside wall face to centre line of flue outlet.

X = Wall thickness.

Y = Distance from wall to edge of air duct on flue elbow.

Z = Distance from centre line of flue outlet to inside wall face.

The maximum flue length with extensions must not be exceeded (refer to L in table below). For each additional 90° or 2 x 45° bends fitted, the maximum flue length must be reduced by 1m. The pipe length is reduced by 500mm for each 45° elbow and 1 m for each 87° elbow used.

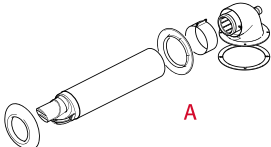
Model	L Max with extensions	X (mm)		Y (mm)	Z (mm)	Horizontal standard flue 0010031041*
		Min	Max			
Energy <sub>7</sub>	10m (Energy)	75	645	65	150	
Compact	9m (Compact)					

\*White terminal as standard, for black terminal use 0020219538.

### Horizontal accessories

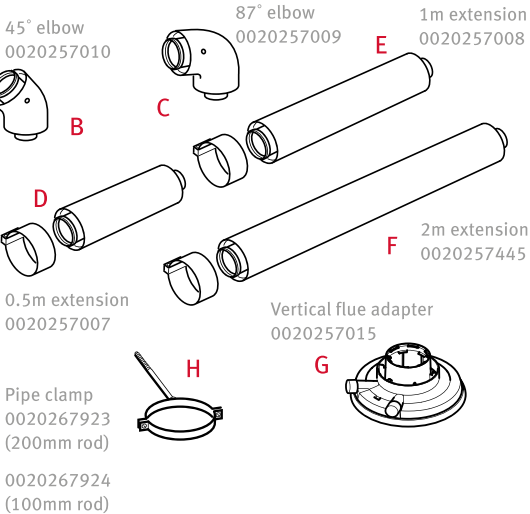

### Flueing examples using extensions and bends

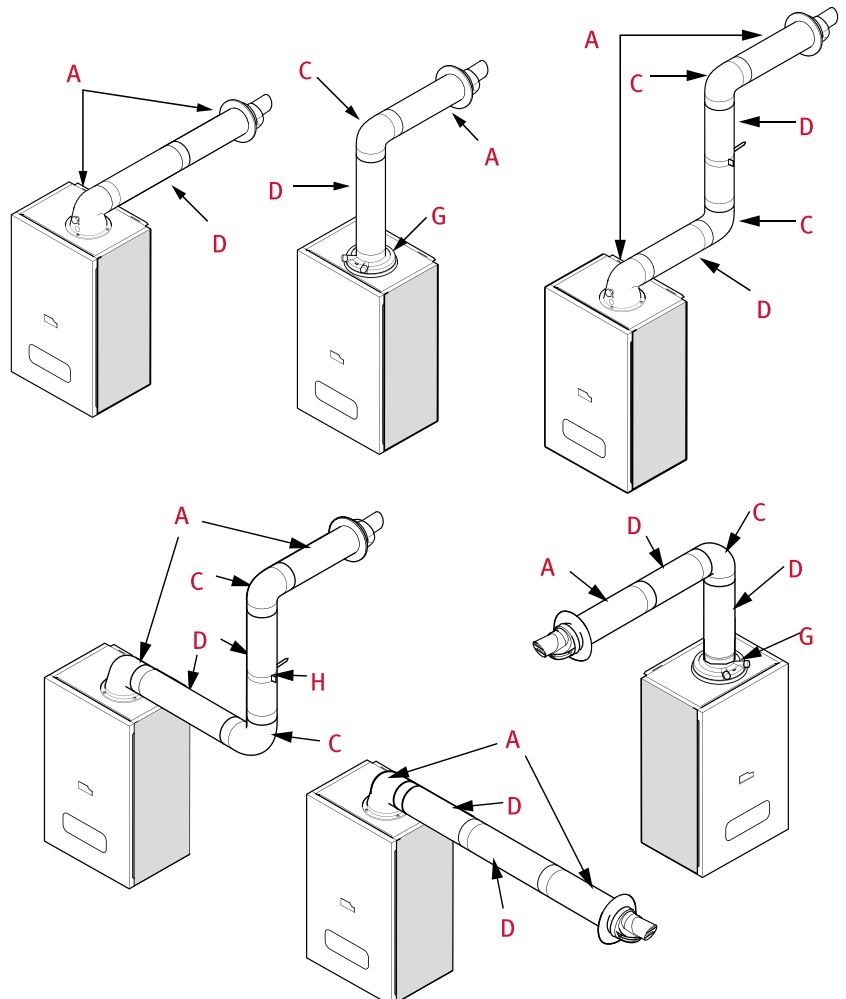

# Telescopic rear flue options

	Model	Max extensions	Min	Max	A Direct rear flue telescopic 0020219526
	Energy <sub>7</sub>	No extensions	480mm	710mm	 Black terminal only

Please note:  
other rear flue options available.

# Vertical flue options

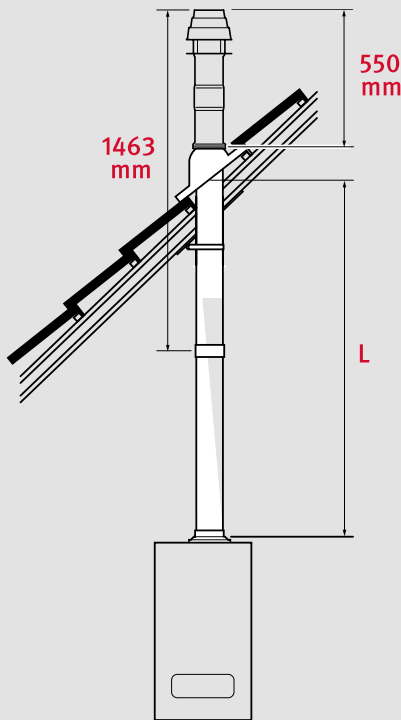

L = Flue length, measured from the top of the boiler to the underside of the roof flashing.

Maximum flue length is 10m plus external vertical roof terminal.

The maximum flue length must not be exceeded (refer to L in table below).

For each additional 90° or 2 × 45° bends fitted, the maximum flue length must be reduced by 1m. The pipe length is reduced by 500mm for each 45° elbow and 1m for each 87° elbow used.

Vertical flue options use the same 100mm diameter flue components as the horizontal flue options.

The vertical flue adaptor G is required for vertical installations.

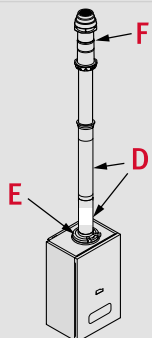
	Model	L Max with extensions	Description of parts	Part number
	All models	10m	0.5m extension	0020257007
			1m extension	0020257008
			2m extension	0020257445
			Vertical flue adaptor	0020257015
Vertical flue terminal, black			0020230604	

## Vertical accessories

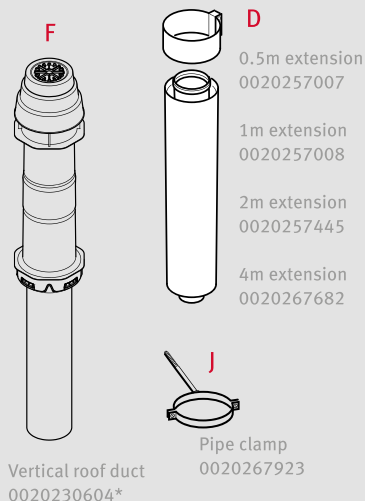

## Flueing examples using extensions and bends

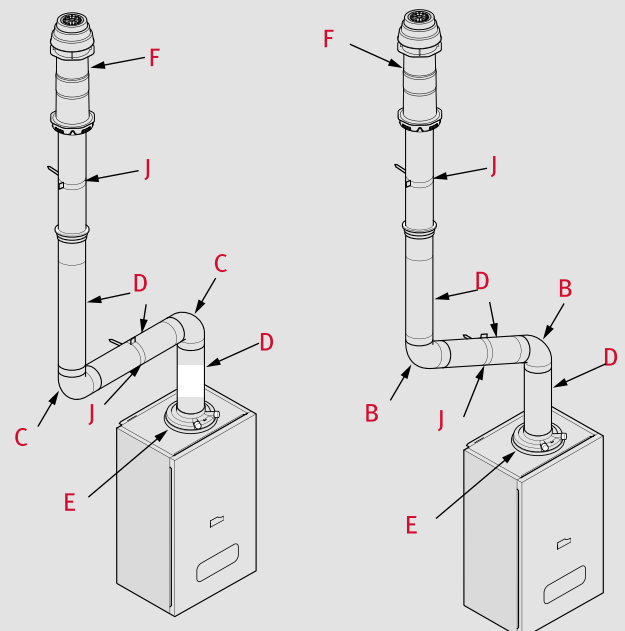
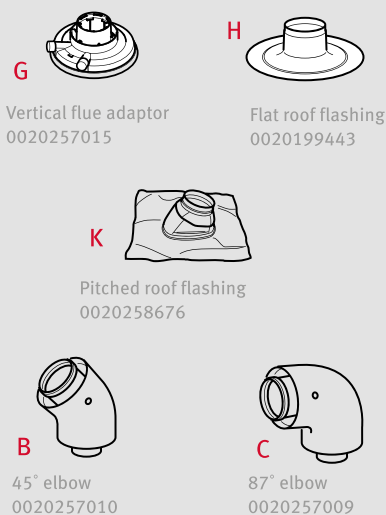

\*Vertical flue adaptor (item G) not included. Must be ordered separately.

# The right part for every job



Part number	Description
0010031041	Horizontal flue kit DN 60/100
0010031043	Horizontal telescopic flue kit DN 60/100
0010031044	Horizontal flue kit 1.7 m DN 60/100
0020219526	Rear telescopic flue kit DN 60/100*
0020219538	Flue terminal kit, black
0020257015	Vertical flue adaptor DN 60/100
0020230604	Vertical flue terminal, black
0020199443	Flat roof flashing
0020258676	Pitched roof flashing
0020257007	Extension 0.5m DN 60/100 PP
0020257008	Extension 1.0m DN 60/100 PP
0020257445	Extension 2.0m DN 60/100 PP
0020267682	Extension 4.0m N 60/100 PP
0020257009	Elbow 87 deg DN 60/100 PPV
0020257010	Elbow 45 deg DN 60/100 PP (2 pieces)
0020267923	Flue support clips 200mm DN 100 (5 pieces)
2000460487	Sliding sleeve DN 60/100
0020267683	Extension 0.5 to 0.8m telescopic 60/100 PP
0020267924	Flue support clips 100mm (pack of 5)
0020219531	Plume management kit, black
0020219532	Plume management kit, white
0020219535	Plume deflector kit, black
0020219536	Plume deflector kit, white
0020219541	PMK extension 1m, black
0020219542	PMK extension 1m, white
0020219545	PMK elbow 87 deg, black
0020219550	PMK elbow 87 deg, white
0020257019	Extension 0.5m N 80/125 PP
0020257020	Extension 1.0m DN 80/125 PP
0020257018	Horizontal air/flue DN 80/125 PP
0020257016	Roof terminal black N 80/125 PP
0020104553	Extension 0.5m N 80/125
0020104554	Extension 1.0m N 80/125

Part number	Description
0020257021	Extension 2.0m N 80/125 PP
0020257023	Elbow 87 deg DN 80/125 PP
0020257024	Elbow 45 deg DN 80/125 PP (2 pieces)
0020257022	Sliding Sleeve DN 80/125 PP
0020104559	Flue support clips (5 off) DN 80/125
0020276091	Vertical flue adaptor N 80/125
0020193663	Upward piping kit
A2044800	Condensate pump
0020193659	Pipe cover plate, small
0020193660	Spacing frame, small*
0020082851	Spacing frame, large**
0010035820	Glow-worm Power System Filter
0010037590	Seal Kit
0020260999	MiSet (wired)
0020261004	MiSet (wireless)
0020266792	Wired outdoor sensor with 15m cable
0020266793	Wired outdoor sensor
0020260987	SR 92
0010035749	MiGo Select
0010038368	MiGo Link internet gateway
8000015471	MiGo Select and MiGo Link internet gateway bundle
0010040290	SRA 42
0010048394	SR 52 repeater
0020135101	Smart Wiring Centre 3

\*Compatible with the Energy range only.

\*\*Combi and System only.

# Thousands of spares in your pocket

Spare parts are like films: the originals are always the best. Original Glow-worm spare parts comply with industry standards and safety tests because they're tested in conjunction with the boilers they're manufactured for. You can have confidence they'll work every time and with availability for up to 15 years after product manufacture ends, you'll always find what you need.

## Innovative new features now available:



Improved camera function to allow you to scan all code types. Including QR codes, barcodes & 3D codes.



Optimised automatic search for equipment and spare parts.



Fault code feature, enter the 2-digit fault code and the app will suggest root causes and solutions.

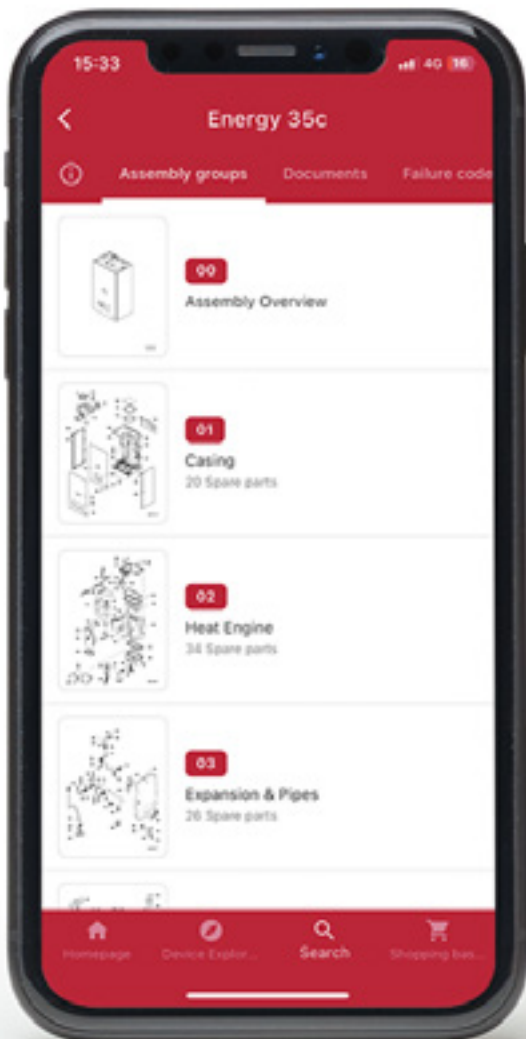

## Spares as reliable as the products they're manufactured for

Original Glow-worm spare parts:

- Comply fully with industry standards and safety tests
- Tested in conjunction with the products they're made for
- Availability for up to 15 years after the product manufacture ends

Search 'spareCHECK' on the app stores or scan the QR code:



Download on the  
App Store



GET IT ON  
Google Play

# Training with Glow-worm

As part of our mission to Keep Britain Glowing, we offer a range of courses to support our installers. We're able to offer both in-person and on-demand courses, giving you the opportunity to tailor your journey around what suits you.



## Why train with us?



### Hands-on approach

Our training facilities are all equipped with live products for you to work on, creating a truly practical approach to training.



### Years of expertise

You'll be in safe hands with our training team, who have hundreds of years combined expertise between them.



### Club Energy rewards

Earn as you learn with cashback, credits and exclusive offers when you train with us.



### Continuous support

Our training team are on hand to share their knowledge whenever you need support with your learning.



### Nationwide training

We have eight training facilities across the UK, which are equipped with the full Glow-worm product portfolio to support your learning.



### Courses for any skill level

Whether you're an apprentice or a Glow-worm expert, we can provide training that is right for you. For more information on our courses, please visit our website.

## Learn around the clock with the Glow-worm Academy

The Glow-worm Academy offers a convenient online platform with training options tailored to you and your business needs. No matter the time of day, the tools are there for you to expand your technical knowledge to help Keep Britain Glowing.



### Sign up today!

Scan the QR code to see all of our courses on offer.

## Join today to benefit from:



Trainer-led learning



No costs, no obligations



Online lessons



Guided learning paths



Webinars



Club Energy rewards



# Glow-worm's training Centres of Excellence



Find out more about our Centres of Excellence



## Contact us

For more information on training centres and courses in your area.

Phone: 0345 601 8885  
[www.glow-worm.co.uk](http://www.glow-worm.co.uk)



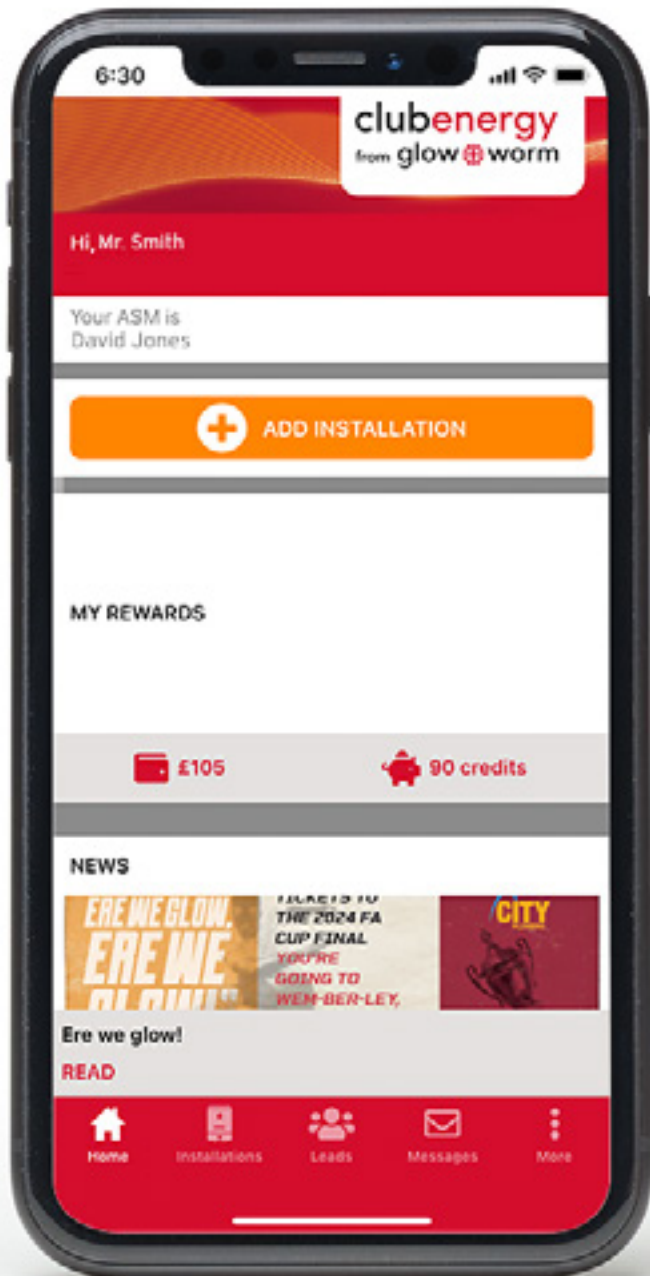

# Club Energy

## A club you can get into wearing work boots

Club Energy, our loyalty scheme for installers, is a pretty exclusive place. As a member, you'll gain access to a full tool bag of benefits, from cash rewards to homeowner leads.

### Join today and make the most of:

- Cash and credit rewards
- Extended product guarantees
- Training courses
- Homeowner leads
- The Club Energy app, making it easy to register boilers, keep track of the latest offers, news and more
- Access to priority numbers for technical and service help

Sign up now at  
[glow-worm.co.uk/clubenergy](http://glow-worm.co.uk/clubenergy)



Download on the  
App Store



GET IT ON  
Google Play

# Imagine having 400 mates on every job

We want all our installers to make the most of all of our products and ensure their customers are happy. So, we're always on hand with the support you need. With a 400 strong UK team comprising of engineers, call centre staff and technical support, we are equipped to support our loyal installers with any queries you may have.

## Technical help

If you have a technical question, get a straightforward solution by contacting our technical helpline on 01773 828300, emailing [technical@glow-worm.co.uk](mailto:technical@glow-worm.co.uk) or visiting our website.

## Genuine high-quality spares

- Spares available for up to 15 years after production ends
- Nationwide spares stockists with over 500 locations
- Next-day delivery service for emergency orders – contact spares on 0345 602 0262 or [spares@glow-worm.co.uk](mailto:spares@glow-worm.co.uk)

## Nationwide after-sales service

- Providing technical help and after-sales service online, over the phone and on the road
- 250 engineers based around the UK, carrying over 1,500 different spare parts
- 97% first time fix rate

For our service department please use the contact details below.

**0330 100 7678**

[customerservice@glow-worm.co.uk](mailto:customerservice@glow-worm.co.uk)

## Literature for your customers

There are a number of easy ways for you to access Glow-worm product and homeowner literature:

- Call 01773 596105
- Download online at [glow-worm.co.uk](http://glow-worm.co.uk) or from Club Energy

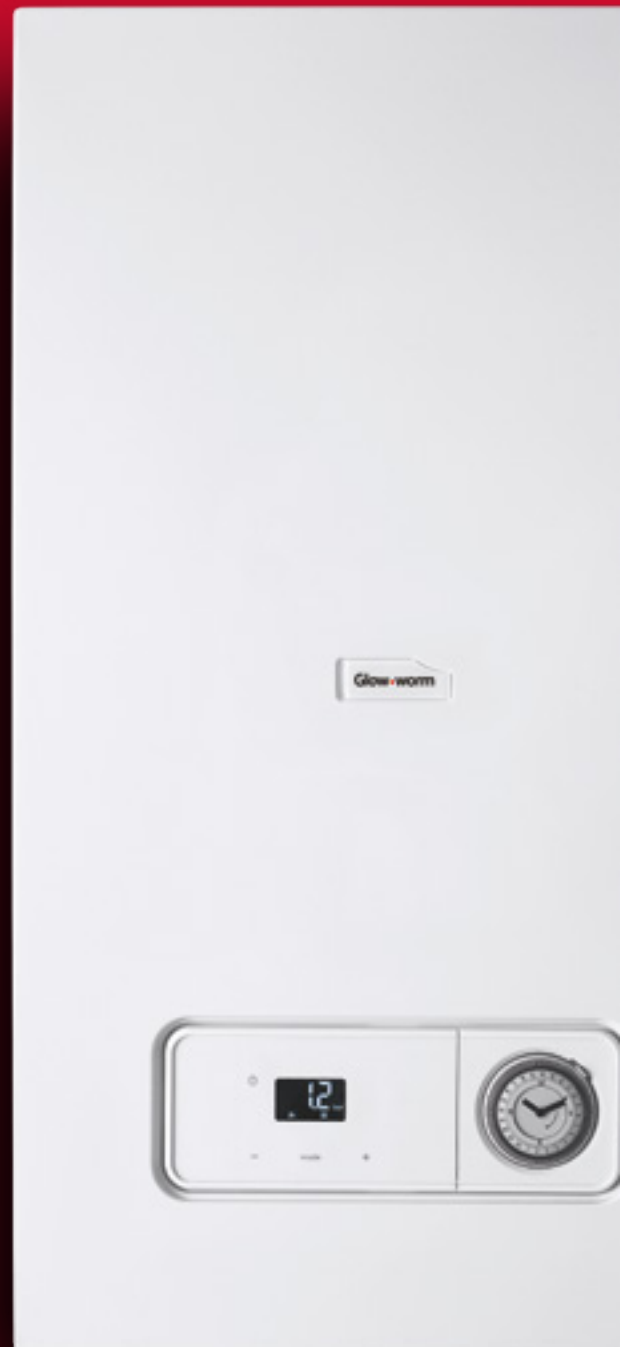

**Head office**  
01773 824639  
info@glow-worm.co.uk

**Literature**  
01773 596105  
literature@glow-worm.co.uk

**Service department**  
0330 100 7678  
customerservice@glow-worm.co.uk

**Installer technical support**  
01773 828300  
technical@glow-worm.co.uk

**Training**  
0345 601 8885  
training@glow-worm.co.uk

**Sales enquiries**  
0345 602 0262  
spares@glow-worm.co.uk

**Club Energy**  
0330 678 1414  
clubenergy-support@glow-worm.co.uk

## **Glow-worm**

Nottingham Road  
Belper  
Derbyshire  
DE56 1JT

 @glow\_wormclub

 @GlowWormHeating

 @glowworm\_uk

 GlowWormGroup

glow-worm.co.uk

GWBROB2BPC0524