

Ultimate₂

Technical boiler guide



Ultimate₂

The Ultimate₂ is Glow-worm's high performance ErP A rated boiler range developed for the one off installer market, and exclusively manufactured for City Plumbing Supplies.

Designed using automotive grade aluminium the Ultimate₂ heat exchanger is a high quality, high efficiency product that makes the boiler not only light to install but also easy to maintain.

The Ultimate₂ range offers a choice of combi, system and regular (open vent) options and is compatible with the full range of Glow-worm controls including the popular MiGo app based control.

The Ultimate₂ also comes with a free 5 year warranty when registered through Club Energy; where installers can also benefit from business tools including the Plumbing Toolbox app, Gas Safe Notifications, Benchmark and some great rewards.



Exclusive City Plumbing Supplies product range
Caters for popular heat output demands and system requirements.



High quality automotive grade aluminium heat exchanger
Designed to last longer, easy to maintain, ultra quiet and reduces customers' energy bills.



Modern bright LCD display
Modern bright LCD display making it easy to change and confirm settings wherever it is installed.



High Efficiency modulating Grundfos pump
Lower running costs as pump adapts to actual heating and hot water demand.



ErP A rated
New high efficiency boiler range with A rated label to meet ErP legislation. Comes with online labelling tool for installers.



Compatible with full range of Glow-worm controls including the MiGo app based control for added efficiency.



Supported by clubenergy
£15 cash reward, full suite of business support tools including Plumbing Toolbox App making installation easier.



Guaranteed for 5 years
5 year parts & labour guarantee comes as standard when registered through Club Energy, with options to extend.



£15 cash reward when registered through Club Energy



FREE 5 year warranty with extended options*



ErP A rated



Ultra quiet operation



Easy to install and service



Product Features & Benefits

- Combi boiler range with choice of 30, 35 kW outputs
- Modern bright LCD display with easy to use interface
- High quality automotive grade aluminium heat exchanger providing excellent performance
- High efficiency, A rated boiler for ErP energy labelling to reduce energy bills
- Grundfos modulating pump for reduced energy use
- Manual pressure gauge to make installation easy
- Uses familiar Glow-worm diagnostics for easy install & servicing
- Inbuilt filling loop

- Compatible with full range of Glow-worm controls, flues and accessories
- Ideal for use with innovative MiGo app based control
- 5 years parts and labour guarantee with option to extend*
- Telescopic flue option available
- Ø60/100 and Ø80/125 flue options available
- Wide range of accessories available including spacing frame and pipe cover plate
- Plume Management kit compatible

*When registered through Club Energy

Ultimate₂ combi boiler

The Ultimate₂ combi boiler provides central heating and hot water without the need for a cylinder to store water. The Ultimate₂ combi is available in a choice of 30kW and 35kW models and features high DHW flow rates, flexible flue options and an aluminium heat exchanger for proven reliability and performance. The Ultimate₂ also features a Grundfos modulating pump for reduced energy use and a modern bright LCD display with an easy to use interface.



Ultimate ₂ combi boiler	30kW	35kW
Casing dimensions (h w d)	740mm x 418mm x 300mm	740mm x 418mm x 300mm
DHW flow rate storage/combi (l/min, 35°C rise)	12.5	14.4
60/100 Flue Length		
Horizontal	9m	9m
Vertical	9m	9m
SEDBUK 2009 annual efficiency (%)	89.3	89.2
ErP Rating Heating	A	A
ErP Rating DHW	A	A

Accessories

Ultimate₂ has a great choice of intelligent controls and accessories to deliver the most efficient heating system for your customers.



MiGo
WiFi connected, app based control



Climapro₂ RF
wireless programmable room thermostat



Climapro₁
programmable room thermostat



Climastat
Easy to use digital heating thermostat



Timer
Plug in analogue timer

Ultimate₂ combi boiler Technical specifications

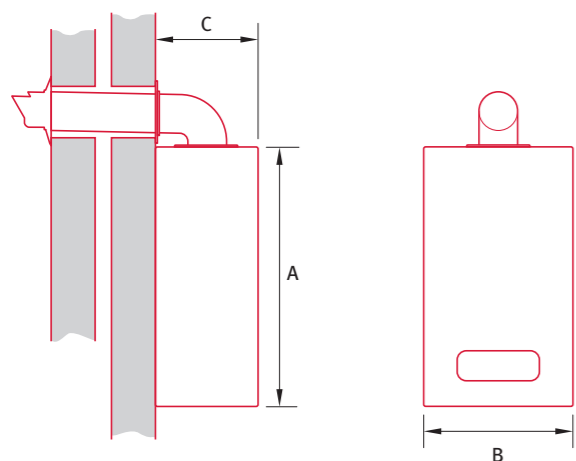
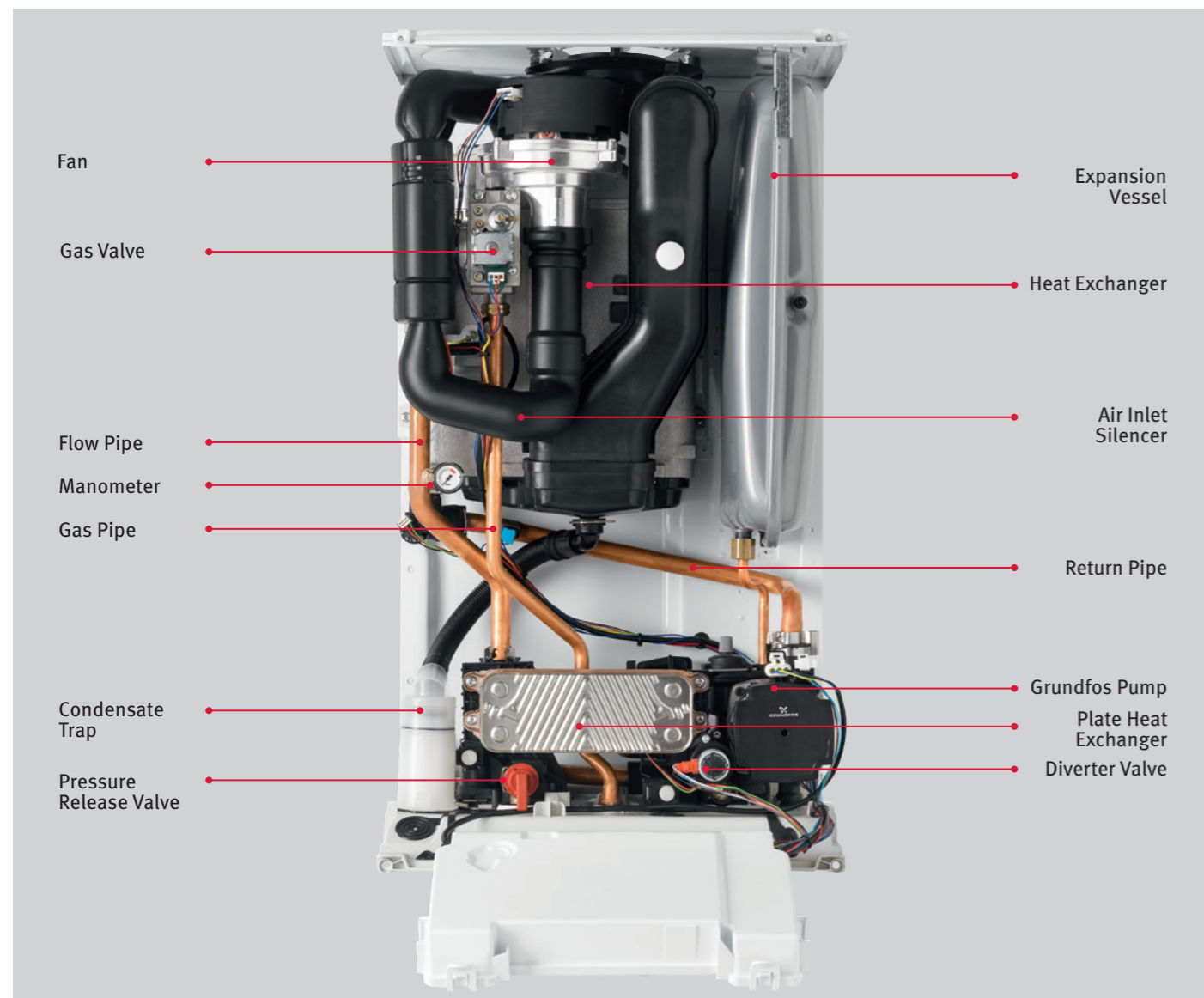

Boiler dimensions

Height (A)	Width (B)	Depth (C)
740mm	418mm	300mm

Ultimate₂ combi boiler Technical specifications



Ultimate ₂ combi boilers	30C	35C
Casing dimensions (h w d) (mm)	740 x 418 x 300	740 x 418 x 300
Weight (lift) (kg)	33	33
Performance		
CH output (kW) Min/Max	6.1/25.5	7.1/25.5
DHW output (kW) CH output (kW) Min/Max	6.1/30.6	7.1/35.7
DHW flow rate storage/combi (l/min. 35°C rise)	12.5	14.4
SEDBUK rating 2009	89.3	89.2
NOx class 5 (natural gas)	Yes	Yes
LPG compatible	No	No
ErP Rating Heating	A	A
ErP Rating DHW	A	A
Construction		
Heat exchanger material	Aluminium	Aluminium
Burner type	Pre-mixed	Pre-mixed
Fully modulating	Yes	Yes
DHW plate heat exchanger	Yes	Yes
Integrated hydrobloc	Yes	Yes
Installation		
Suitable for sealed systems	Yes	Yes
Inbuilt filling loop	Integrated	Integrated
Inbuilt adjustable system bypass	Yes	Yes
Inbuilt condensate trap/siphon	Yes	Yes
Inbuilt boiler frost protection	2 stage	2 stage
Zero compartment ventilation	Yes	Yes
Pump	ErP fully modulating Grundfos	ErP fully modulating Grundfos
Clearances		
Top (mm) (from top of boiler)	300	300
Side (mm)	0*	0*
Bottom (mm)	300	300
Front (mm) ²	600**	600**
User Interface		
User display	Super Bright LCD	
Diagnostics	Advanced	Advanced
User adjustable CH temp control	Yes	Yes
User adjustable DHW temp control	Yes	Yes
Pipes		
Water connections	2x22/2x15mm	2x22/2x15mm
Flues		
Max horizontal ø60/100	9m	9m
Max vertical ø60/100	9m	9m
Max horizontal ø80/125	25m	25m
Max vertical ø80/125	25m	25m
Optional plume management kit ø60/100	Yes	Yes
Optional spacing frame	Yes	Yes

*See manual for clearance if side panels are to be removed to assist future service and maintenance
**5mm if removable panel or door



£15 cash reward when registered through Club Energy



FREE 5 year warranty with extended options*



ErP A rated



Ultra quiet operation



Easy to install and service



Product Features & Benefits

- Sealed system in 25 kW output
- Modern bright LCD display with easy to use interface
- High quality automotive grade aluminium heat exchanger providing excellent performance
- High efficiency, A rated boiler for ErP energy labelling to reduce energy bills
- Grundfos modulating pump for reduced energy use
- Manual pressure gauge to make installation easy
- Uses familiar Glow-worm diagnostics for easy install & servicing
- Inbuilt filling loop
- Compatible with full range of Glow-worm controls, flues and accessories
- Ideal for use with innovative MiGo app based control
- 5 years parts and labour guarantee with option to extend*
- Telescopic flue option available
- ø60/100 and ø80/125 flue options available
- Wide range of accessories available including spacing frame and pipe cover plate
- Plume Management kit compatible

*When registered through Club Energy

Ultimate₂ system boiler

The Ultimate₂ System boiler is suitable for homes with high hot water demands. The Ultimate₂ system is a sealed system that comes in a 25kW output and features flexible flue options and an aluminium heat exchanger for proven reliability and performance. The Ultimate₂ also features a Grundfos modulating pump for reduced energy use and a modern bright LCD display with an easy to use interface.



Ultimate ₂ system boiler	25kW
Casing dimensions (h w d)	740mm x 418mm x 300mm
60/100 Flue Length	
Horizontal	9m
Vertical	9m
SEDBUK 2009 annual efficiency (%)	89.3
ErP Rating	A

Accessories

Ultimate₂ has a great choice of intelligent controls and accessories to deliver the most efficient heating system for your customers.



MiGo
WiFi connected, app based control



Climapro₂ RF
wireless programmable room thermostat



Climapro₁
programmable room thermostat



Smart Wiring Centre₂
multi zone intelligent wiring centre



Timer
Plug in analogue timer

Ultimate₂ system boiler Technical specifications

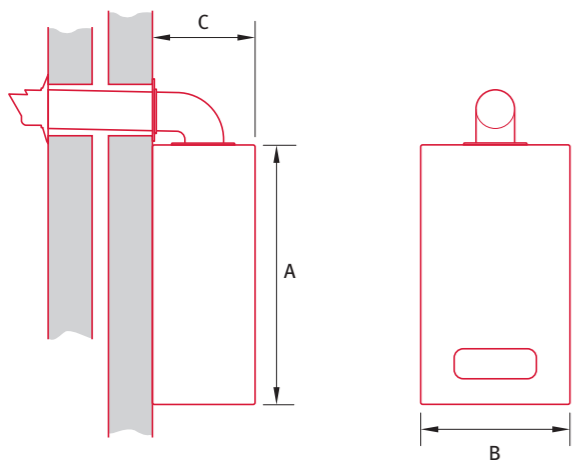
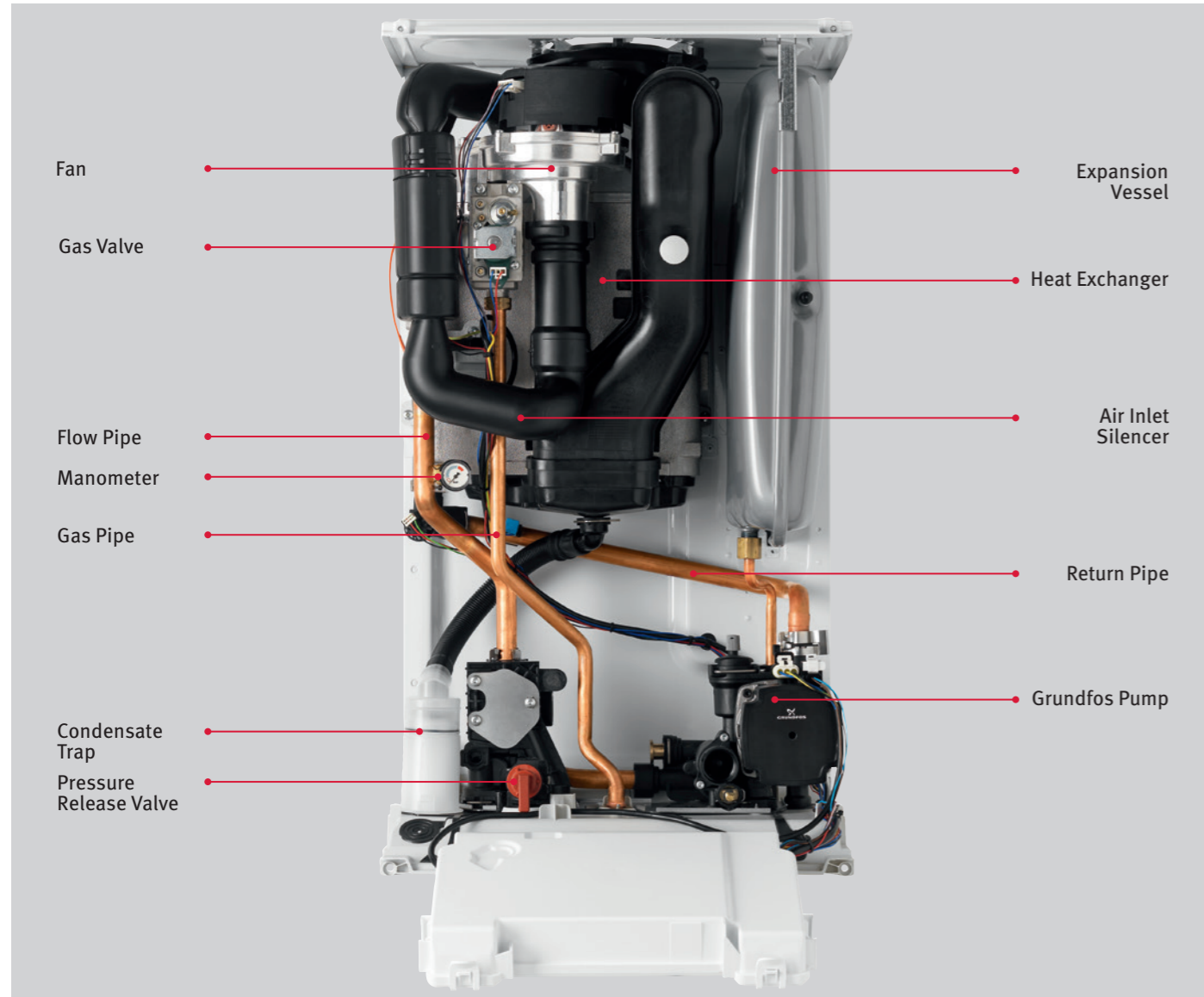

Boiler dimensions

Height (A)	Width (B)	Depth (C)
740mm	418mm	300mm

Ultimate₂ system boiler Technical specifications



Ultimate ₂ system boiler	255
Casing dimensions (h w d) (mm)	740 x 418 x 300
Weight (lift) (kg)	32
Performance	
CH output (kW) Min/Max	6.1/25.5
SEDBUK rating 2009	89.3
NOx class 5 (natural gas)	Yes
LPG compatible	No
ErP Rating	A
Construction	
Heat exchanger material	Aluminium
Burner type	Pre-mixed
Fully modulating	Yes
DHW plate heat exchanger	Yes
Integrated hydrobloc	Yes
Installation	
Suitable for sealed systems	Yes
Inbuilt filling loop	Integrated
Inbuilt condensate trap/siphon	Yes
Inbuilt boiler frost protection	2 stage
Zero compartment ventilation	Yes
Pump	Grundfos
Clearances	
Top (mm) (from top of boiler)	300
Side (mm)	0*
Bottom (mm)	300
Front (mm) ²	600
User Interface	
User display	Super Bright LCD
Diagnostics	Advanced
User adjustable CH temp control	Yes
Pipes	
Water connections	2x22/2x15mm
Flues	
Max horizontal ø60/100	9m
Max vertical ø60/100	9m
Max horizontal ø80/125	25m
Max vertical ø80/125	25m
Optional plume management kit ø60/100	Yes
Optional spacing frame	Yes

*See manual for clearance if side panels are to be removed to assist future service and maintenance
**5mm if removable panel or door



£15 cash reward when registered through Club Energy

FREE 5 year warranty with extended options*

ErP A rated

Ultra quiet operation

Easy to install and service



Product Features & Benefits

- Regular 25 kW output with small compact cupboard fit dimensions
- Modern bright LCD display with easy to use interface
- High quality automotive grade aluminium heat exchanger providing excellent performance
- High efficiency, A rated boiler for ErP energy labelling to reduce energy bills
- Uses familiar Glow-worm diagnostics for easy install & servicing
- Compatible with full range of Glow-worm controls, flues and accessories

- Ideal for use with innovative MiGo app based control
- 5 years parts and labour guarantee with option to extend*
- Telescopic flue option available
- Ø60/100 and Ø80/125 flue options available
- Wide range of accessories available including spacing frame and pipe cover plate
- Plume Management kit compatible

*When registered through Club Energy

Ultimate₂ regular boiler

The Ultimate₂ regular (open vent) boiler is suitable for homes with high hot water demands. The Ultimate₂ regular heat only boiler is available in a 25kW output and has been designed to be light and compact with cupboard fit dimensions. The boiler features flexible flue options and an aluminium heat exchanger for proven reliability and performance.



Ultimate ₂ regular boiler	25kW
Casing dimensions (h w d)	600mm x 375mm x 280mm
60/100 Flue Length	
Horizontal	9m
Vertical	9m
SEDBUK 2009 annual efficiency (%)	89.3
ErP Rating	A

Accessories

Ultimate₂ has a great choice of intelligent controls and accessories to deliver the most efficient heating system for your customers.



MiGo
WiFi connected, app based control



Climapro₂ RF
wireless programmable room thermostat



Climapro₁
programmable room thermostat



Smart Wiring Centre₂
multi zone intelligent wiring centre

Ultimate₂ regular boiler Technical specifications

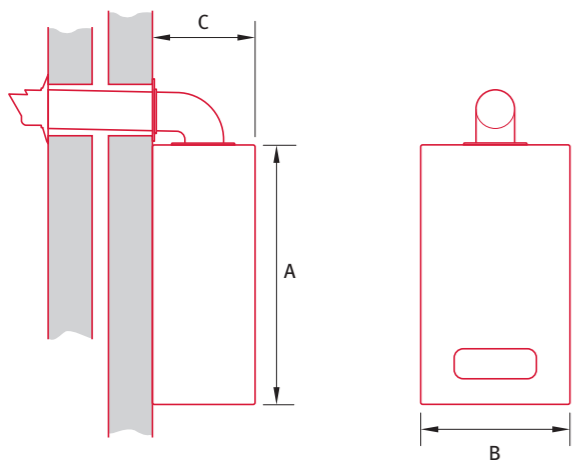
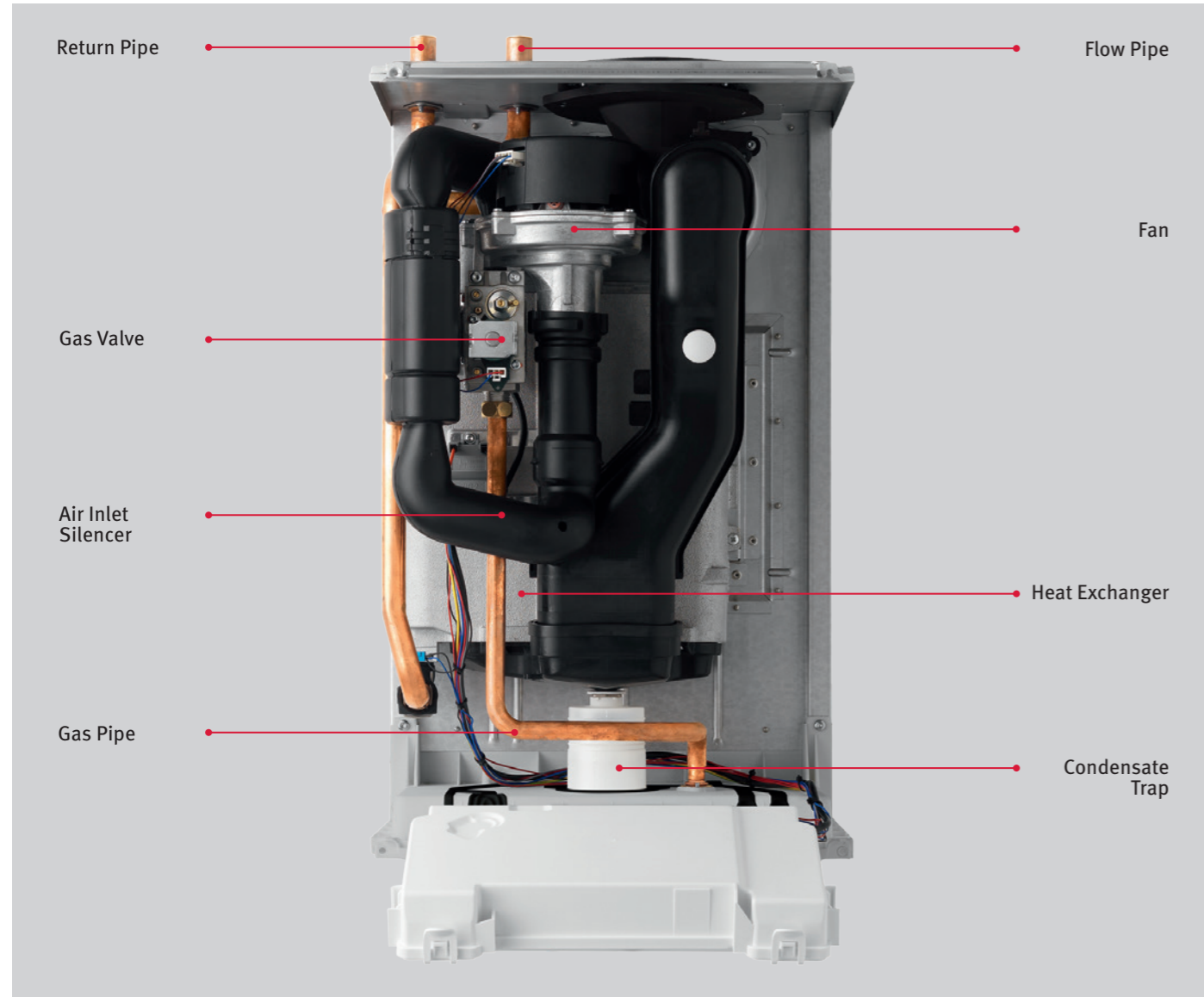

Boiler dimensions

Height (A)	Width (B)	Depth (C)
600mm	375mm	280mm

Ultimate₂ regular boiler Technical specifications



Ultimate ₂ regular boiler	25h
Casing dimensions (h w d) (mm)	600 x 375 x 280
Weight (lift) (kg)	22
Performance	
CH output (kW) Min/Max	6.1/25.5
SEDBUK rating 2009 (%)	89.3
NOx class 5 (natural gas)	Yes
LPG compatible	No
ErP Rating	A
Construction	
Heat exchanger material	Aluminium
Burner type	Pre-mixed
Fully modulating	Yes
Installation	
Inbuilt condensate trap/siphon	Yes
Inbuilt boiler frost protection	2 stage
Zero compartment ventilation	Yes
Clearances	
Top (mm) (from top of boiler)	300
Side (mm)	0*
Bottom (mm)	300
Front (mm) ²	600**
User Interface	
User display	Super Bright LCD
Diagnostics	Advanced
User adjustable CH temp control	Yes
Pipes	
Water connections	2x22mm
Flues	
Max horizontal ø60/100	9m
Max vertical ø60/100	9m
Max horizontal ø80/125	25m
Max vertical ø80/125	25m
Optional plume management kit ø60/100	Yes
Optional spacing frame	Yes

*See manual for clearance if side panels are to be removed to assist future service and maintenance
**5mm if removable panel or door

Intelligent controls

All Glow-worm controls have been designed to work exclusively with the Ultimate₂ range of boilers, so they are simple to install and your customer will get the ultimate in running efficiency, convenience and comfort. The Ultimate₂ is compatible with the full range of Glow-worm controls.

The world of controls explained

Weather compensation uses our outdoor sensor to measure outside temperature and adjusts the flow temperature to meet daily heating demands. The colder it is outside, the hotter the flow temperature to the radiators. As the weather gets warmer the flow temperature is cooler. This ensures the boiler operates in the most efficient way to maintain stable temperature levels and lower energy bills further.

Plug in timer and Climastat Thermostat

- Wall mounted Climastat connects using simple low voltage eBus
- Traditional interface for customers to set heating programmes
- eBus connected Climastat means the boiler will modulate to manage heating in the most efficient way possible
- Heating & hot water mode on indicator
- Service, fault and maintenance indication
- Clear digital display with 0.5°C temperature intervals
- Wide temperature range 5 – 30°C



ErP Class
V
+3%

Plug in Timer	
Room Thermostat	
Programmable Room Thermostat	✓
Wireless controls	
Load Compensation	✓

Weather compensation not possible

Climapro₁ Wired & Wireless Programmable Thermostat

- Secure wall mounted thermostat is wired using simple low voltage eBus
- User friendly design with bright backlight
- Clear straightforward menus to set heating & hot water programmes
- Annual service reminder and auto daylight saving time
- eBus connected Climapro₁ means the boiler will modulate to manage heating in the most efficient way possible
- Weather compensation using a simple wireless outdoor sensor
- Climapro₁ RF wireless version available
- Climapro₁ wired version can be used with the smart wiring centre to offer two heating and one hot water zone. (S Plan Plus)
- Automatic daylight savings time



ErP Class
VI
+4%*

Plug in Timer	
Room Thermostat	
Programmable Room Thermostat	✓
Wireless controls	
Load Compensation	✓
Weather Compensation*	✓

*When an outdoor sensor is included

*Class VI possible when used with outdoor sensor

Climapro₂ Wireless Programmable Thermostat

- Wireless thermostat works anywhere in the home
- Wall bracket for base location and secure storage
- RF receiver slots into the boiler, simple wireless setup, no electrician required
- User friendly design with bright backlight
- Clear straightforward menus to set heating & hot water programmes
- Annual service reminder and auto daylight saving time
- eBus connected Climapro₂ RF means the boiler will modulate to manage heating in the most efficient way possible
- Weather compensation using a simple wireless outdoor sensor

ErP Class
VI
+4%*



Plug in Timer	
Room Thermostat	
Programmable Room Thermostat	✓
Wireless controls	✓
Load Compensation	✓
Weather Compensation*	✓

*When an outdoor sensor is included

MiGo App based programmable room thermostat

- Smart phone App for Apple & Android devices to manage heating & hot water on the go.
- Simple & straightforward installation - Installed and running in less than 30 minutes
- Easy & intuitive interface - Fast and straightforward temperature control
- Self learning - MiGo automatically learns the energy requirements of your home
- Installation assistant – Seriously simple step by step pairing process
- Internet weather compensation - MiGo only ever uses your energy as and when it needs to without the need for an outside temperature sensor
- Energy consumption monitoring - Gas and electricity consumption for both heating and DHW
- eBUS communication - MiGo and Glow-worm boilers speak the same 'language'!
- One heating circuit and DHW management - DHW and central heating control from one device
- In room thermostat can be wall mounted or a portable table top version
- Electronic paper display – Clear display with low energy consumption
- Multi user sharing and multi-home control - You and your family can manage several heating systems for the same or different locations



ErP Class
V
+4%

Plug in Timer	
Room Thermostat	
Programmable Room Thermostat	✓
Wireless controls	✓
Smartphone App controls	✓
Load Compensation	✓
Weather Compensation	✓

Smart Wiring Centre₂ intelligent wiring centre

- Coloured plug-in wiring connections
- eBUS low voltage communication
- Compatible with system and open vent range boiler
- Compact and neat design
- Compatible with traditional heating systems (S & Y Plan)
- Two heating circuit with domestic hot water control. (S Plan Plus) when used with Climapro₁
- Intelligent hot water control



*Class VI possible when used with outdoor sensor

Horizontal flueing options

The horizontal flueing information below applies to the Ultimate₂ range of High Efficiency boilers.

Boiler	Ø60/100 Max horizontal	Ø80/125 Max horizontal
Ultimate ₂ combi 30/35c	9m	25m
Ultimate ₂ system 25s	9m	25m
Ultimate ₂ regular 25h	9m	25m

Notes:
1 The overall maximum flue length must not be exceeded.

Top rear and top side horizontal flue options

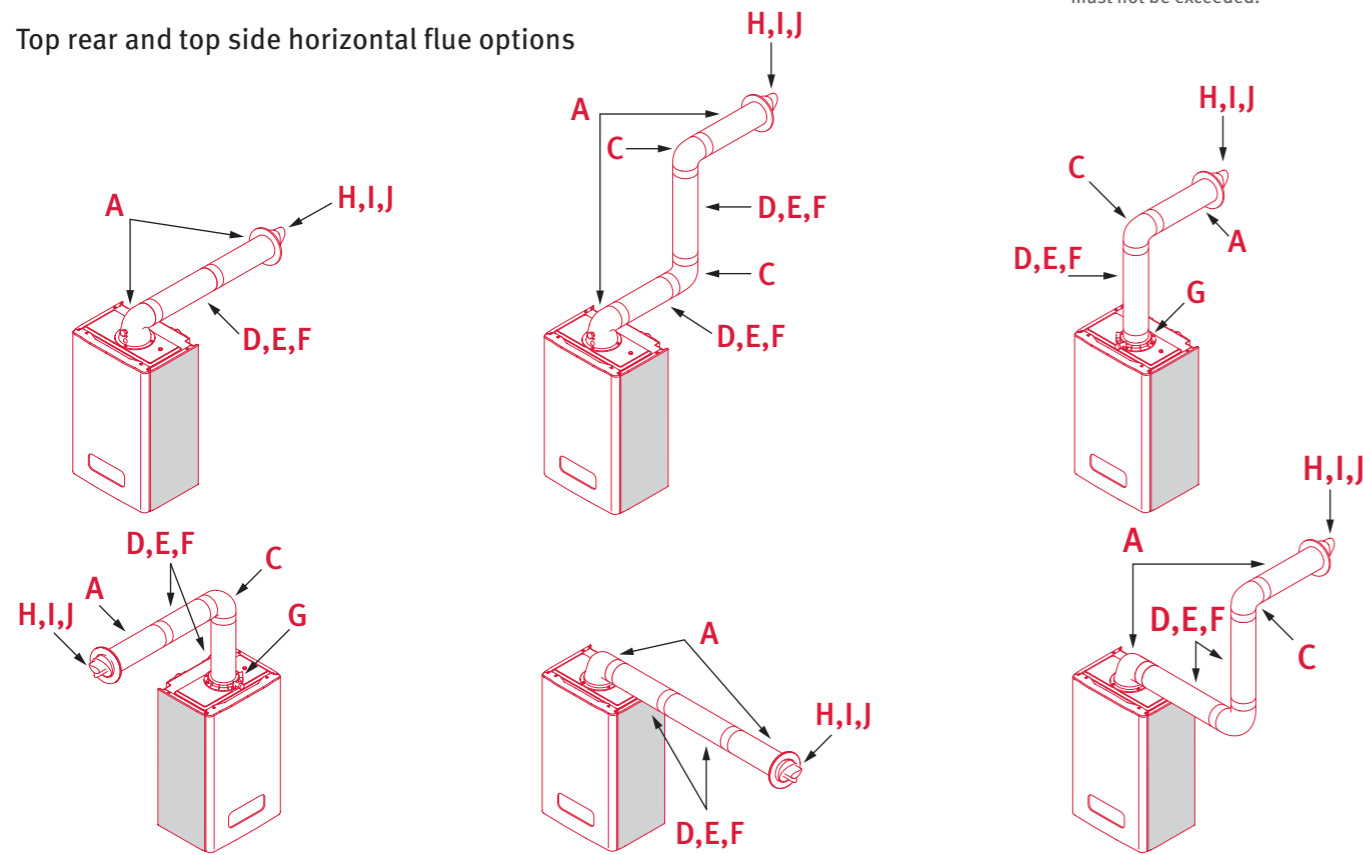

Horizontal flue accessories

Component	Description	Part Number Ø60/100	Part Number Ø80/125
A	Horizontal Telescopic flue	A2043600	0020104551
B	45° Bend (2 off)	2000460485	0020104557
C	90° Bend (1 off)	2000460484	0020104556
D	0.5m Extension (1 off)	2000460481	0020104553
E	1m Extension (1 off)	2000460482	0020104554
F	2m Extension (1 off)	2000460483	0020104555
G	Vertical Flue Adaptor	0020209763	0020209764
H	Deflector Terminal (Black)	0020060582	-
I	Deflector Terminal (White)	0020060583	-
J	Black Terminal	A2043700	-

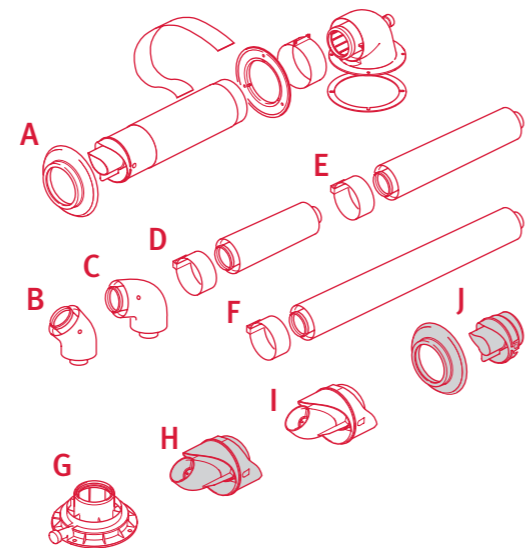

Vertical flueing options

The vertical flueing information below applies to the Ultimate₂ range of High Efficiency boilers.

Boiler	Ø60/100 Max vertical	Ø80/125 Max vertical	Compatible with Plume Management Kit
Ultimate ₂ combi 30/35c	9m	25m	YES
Ultimate ₂ system 25s	9m	25m	YES
Ultimate ₂ regular 25h	9m	25m	YES

Notes:
1 The overall maximum flue length must not be exceeded.

Vertical flue options

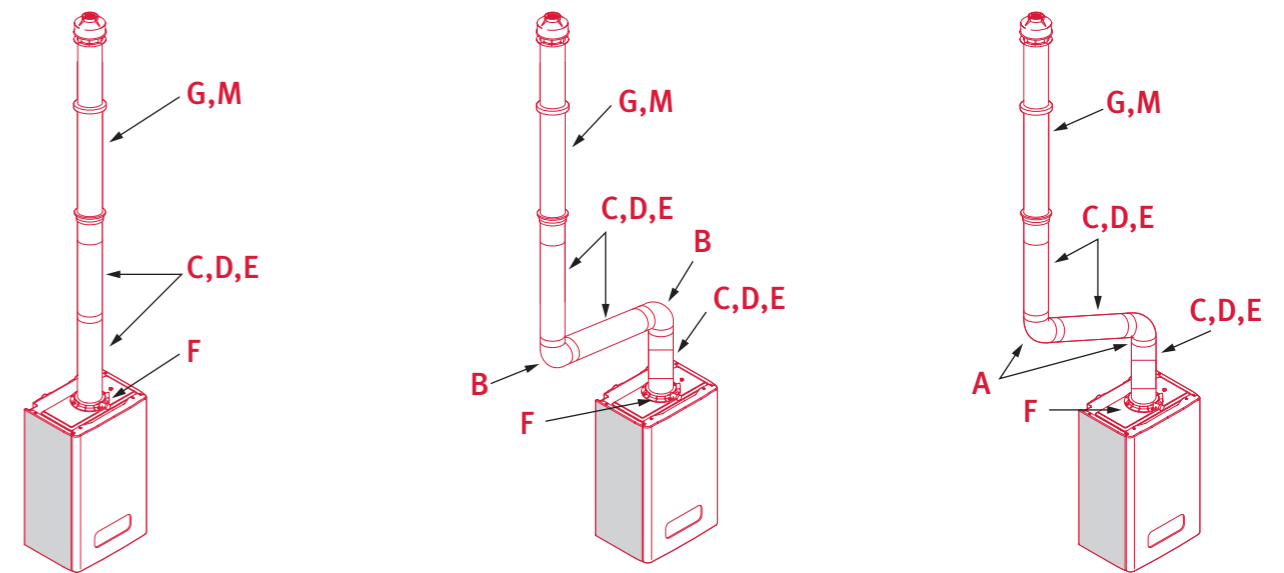

Notes:
i Horizontal sections must have a continuous fall of at least 2.5° (44mm/metre) back to the boiler.

Vertical flue accessories

Component	Description	Part Number Ø60/100	Part Number Ø80/125
A	45° Bend (2 off)	2000460485	0020104557
B	90° Bend (1 off)	2000460484	0020104556
C	0.5m Extension (1 off)	2000460481	0020104553
D	1m Extension (1 off)	2000460482	0020104554
E	2m Extension (1 off)	2000460483	0020104555
F	Vertical Flue Adaptor	0020209763	0020209764
G	Vertical Roof Terminal	2000460480	0020104552
H	Pitched Roof Flashing	2000460479	-
I	Flat Roof Flashing	2000460478	-
J	Sliding Sleeve	2000460487	0020104558
K	Fixing Bracket (5 off)	2000460486	0020104559
L	Telescopic Extension	A2036900	-
M	Ridge Tile Terminal	A2043800	-

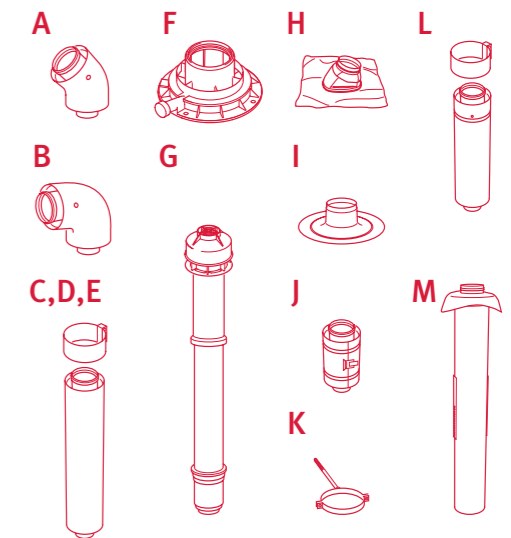

Training

Glow-worm offer a range of online and centre based facilities covering the complete Glow-worm range. To find out more please call 01773 596156 or email training@glow-worm.co.uk

Support

Expert advice and support from installation to maintenance

Technical help

- If you have a technical question simply call our technical help line on 0330 100 7679 or email technical@glow-worm.co.uk for a straightforward answer

Genuine high quality spares

- Spares availability for up to 15 years after production ends
- Nationwide spares stockists with over 500 locations
- Next day delivery service for emergency orders - contact spares on 01773 596 090 or spares@glow-worm.co.uk

Nationwide after sales service

- Supporting you with technical help and after sales service online, over the telephone and on the road
- 250 engineers based around the UK, carrying over 1,500 different spare parts
- 97% first time fix rate

For our service department please call 0330 100 7678 or email customerservice@glow-worm.co.uk



clubenergy

The award winning loyalty programme from Glow-worm

Enjoy great member benefits when you register your Ultimate₂ installations including...

£15 When registered through Club Energy	FREE 5 Year warranty When registered through Club Energy, option to extend	Business Development Free tools to grow your business	Plumbing Toolbox app Industry leading Plumbing Toolbox app making installations easy	Training Free training	Business Tools including instant Gas Safe notifications

Plumbing Toolbox - The industry leading installer App for Club Energy members

Designed to make your working life easier!

The Plumbing Toolbox App includes loads of useful stuff...

Register your Installs	Merchant Locator no more wild goose chases	Fix that fault quick and easy fault code identification
Every manual wherever you are, right there in your pocket	Service Reminders helping to keep you organised	



To find out more about how you can benefit from Club Energy or join free today visit www.clubenergy.co.uk or call 0845 275 7018



Literature

There are a number of easy ways for you to access Glow-worm product literature:

- Via our installer App - Plumbing Toolbox
- Via telephone 01773 596 013
- Available to download online at www.glow-worm.co.uk
- Via email literature@glow-worm.co.uk



Head Office
01773 824 639
info@glow-worm.co.uk

Literature
01773 596 013
literature@glow-worm.co.uk

Service Department
0330 100 7678
customerservice@glow-worm.co.uk

Installer Technical Support
0330 100 7679
technical@glow-worm.co.uk

Training
01773 596 156
training@glow-worm.co.uk

Spare Parts
01773 596 090

Club Energy
01865 893417
clubenergy.co.uk



INVESTOR IN PEOPLE

Glow-worm

Nottingham Road
Belper
Derbyshire
DE56 1JT
www.glow-worm.co.uk